

Aquastream Solar Pump



Simple to operate and easy to maintain, the Aquastream solar pump is well known for its quietness and reliability.

Aquastream solar pumps incorporate essential features required to make them compatible with Zane solar heating systems.



Aquastream Solar Pump

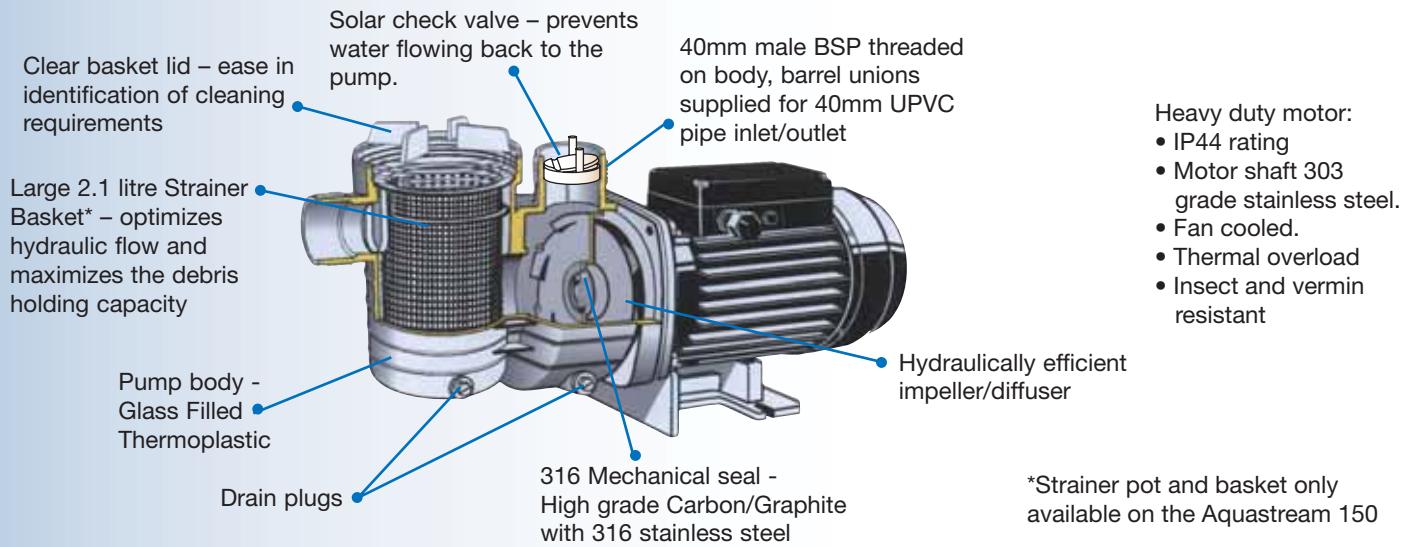

Aquastream 50 - 150 without strainer pot

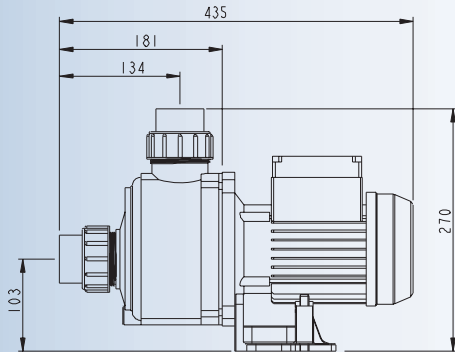

Aquastream 150 with strainer pot

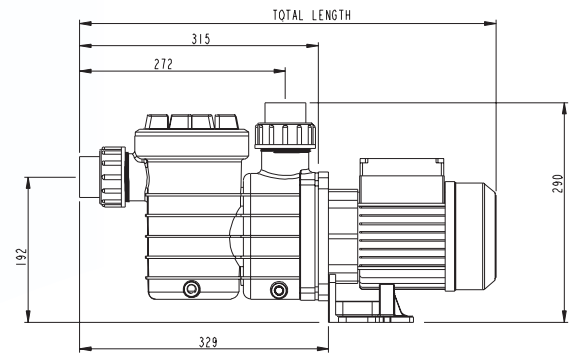

| Model | Nominal HP | kw | Amps | Phase | Volts | Cycle | RPM |
|----------------|------------|------|------|-------|-----------|-------|-------|
| Aquastream 50 | 0.5 | 0.58 | 2.5 | 1 | 220 - 240 | 50 | 22860 |
| Aquastream 75 | 0.75 | 0.65 | 3.0 | 1 | 220 | 50 | 22860 |
| Aquastream 100 | 1.00 | 0.76 | 3.33 | 1 | 220 | 50 | 22860 |
| Aquastream 125 | 1.25 | 0.88 | 3.9 | 1 | 220 | 50 | 22860 |
| Aquastream 150 | 1.50 | 1.15 | 5.0 | 1 | 220 | 50 | 22860 |

Aquastream Solar Pump Performance Chart

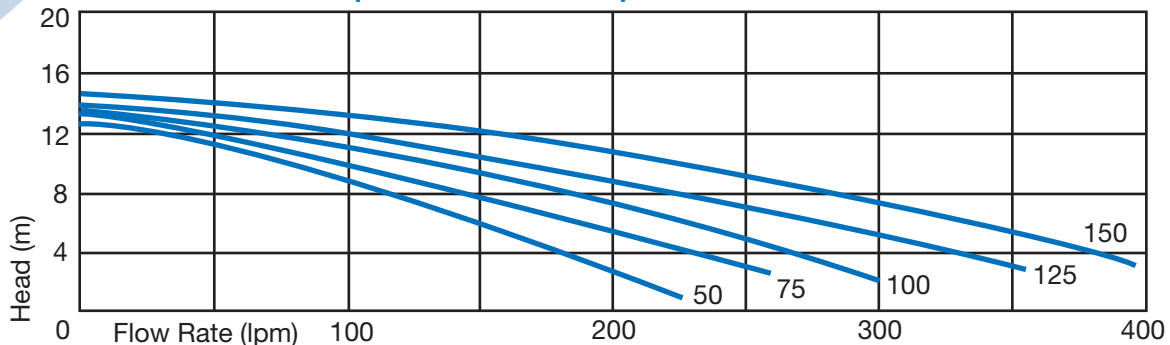

OFFICES - AUSTRALIA

NSW - Sydney (Head Office)
Tel: +61 2 9898 8600
QLD - Brisbane
Tel: +61 7 3299 9900
VIC/TAS - Melbourne
Tel: +61 3 9879 5141
WA - Perth
Tel: +61 8 9273 1900
SA/NT - Adelaide
Tel: +61 8 8244 6000
ACT Distribution
Tel: +61 2 6280 6476

OFFICES - OVERSEAS

Waterco (Europe) Limited
Radfield, Kent, UK
Tel: +44 (0) 1795 521 733
Waterco (USA) Inc
Phoenix, Arizona, USA
Tel: +1 623 434 4703
Waterco USA (Baker Hydro)
Augusta, USA
Tel: +1 706 793 7291
Waterco Canada (Focus Temp)
Quebec, Canada
Tel: +1 450 796 4333

Waterco (NZ) Limited
Auckland, New Zealand
Tel: +64 9 525 5750
Waterco (GZ) Limited
Guangzhou, China
Tel: +86 20 3222 2180
Waterco (Far East) Sdn Bhd
Selangor, Malaysia
Tel: +60 3 6145 6000
PT Waterco Indonesia
Jakarta, Indonesia
Tel: +62 21 4585 1481

DISTRIBUTED BY:

WATERCO
Water, the liquid of life

