



# QUIETLINE PUMPS

## SQL Series

COMMERCIAL/DOMESTIC

High performance  
pool and spa pumps  
delivering more power  
for greater efficiency

POOL AND SPA PUMPS



Quietline Pumps

## Quietline swimming pool and spa pumps

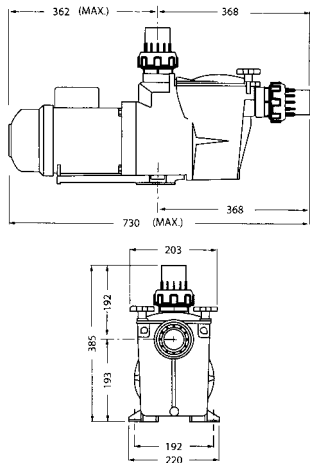
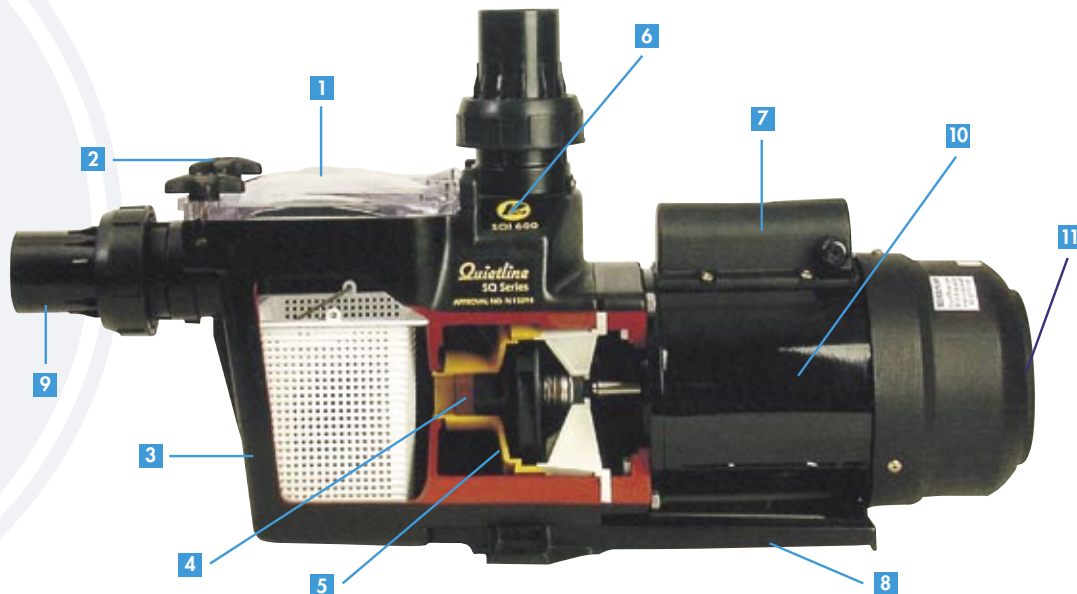

### Quietline product features:

- 1 Clear full-view strainer cover lets you see when the basket needs cleaning.
- 2 Swing – aside knobs makes strainer cover removal easy. No tools required. No loose parts. No clamps. No plastic threads to bind up!
- 3 The large 1800 cubic centimetre capacity hair and leaf strainer basket gives longer periods between cleaning. Rigid construction and load extender ribbing assures free flowing operation with even the heaviest debris loads.
- 4 Corrosion-proof, glass reinforced closed face impeller has smooth wide openings to prevent fouling or clogging. Engineered for maximum performance on both filtration and spa jet applications.
- 5 'Low noise' running achieved with carefully matched diffuser and balanced impeller system. Can be installed close to living areas.
- 6 All components moulded from tough, corrosion-proof engineering resins for extra durability and long life.

- 7 Heavy Duty weatherproof motor with built in thermal overload protection for dependability. Electrically double insulated from pool water for extra safety.
- 8 Moulded mounting feet ensure balanced support for motor and pump.
- 9 Quick-disconnect union adaptors for both suction and discharge ports. Self alignment allows for easy plumbing in either 40mm or 50mm.
- 10 Suitable for either Commercial or Domestic pools. Single or 3 Phase option.
- 11 Rated IP44, which is suitable for installation in the pool zone.

### Pool pump:

Maximum (recommended) number of 10mm Poolrite Venturi Spa Jets for each pump at minimal head loss.

SQI 400	SQI 500	SQI 600	SQI 700
4	5	6	8

Model	HP output	kW output	Min. Suction Pipe Size (mm)
SQI 400	1.0	0.75	40
SQI 500	1.25	0.93	40 to 50
SQI 600	1.5	1.1	40 to 50
SQI 700	2.0	1.5	50 only

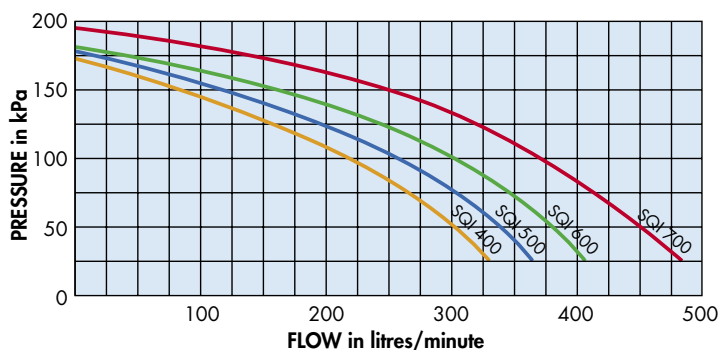

### Shipping specifications:

#### Maximum Weight:

SQI 400	17.80kg	SQI 600	20.40kg
SQI 500	19.40kg	SQI 700	23.60kg

Measure (mm): 720L x 360H x 220W

### WARRANTY:

- 3 years (1 year Mechanical Seal) from date of purchase by original owner.

For good clean fun!



Get it right!

**AUSTRALIA**  
**HEAD OFFICE – QLD:** 415 Creek Road MT GRAVATT 4122  
 Telephone: (07) 3323 6555, Fax: (07) 3323 6500

**Nth QLD:** 36 Hugh Ryan Drive GARBUTT 4814  
 Telephone: (07) 4779 4880, Fax: (07) 4779 6714

**NSW:** 6 Forsyth Close WETHERILL PARK 2164  
 Telephone: (02) 9729 0166, Fax: (02) 9729 2759

**VIC:** 1 Endeavour Way BRAESIDE 3195  
 Telephone: (03) 9588 1770, Fax: (03) 9558 177

**WA:** 16 Ledger Road BALCATT 6021  
 Telephone: (08) 9344 3871, Fax: (08) 9345 3923

**NEW ZEALAND**  
 22/761 Great South Road, Penrose AUCKLAND  
 Telephone (09) 571 0210, Fax: 0800 766 574

Manufactured by Poolrite Equipment Pty Ltd ABN 11 001 674 004 Website: [www.poolrite.com.au](http://www.poolrite.com.au) Email: [info@poolrite.com.au](mailto:info@poolrite.com.au)

Manufacturer reserves the right to alter specifications without notice.