

# SPECK SUPER 90 SERIES

The Speck SUPER 90 Series is the all-round swimming pool and spa pump. Great performance makes it the ultimate choice for pools and spas with a wide range of applications including solar heating and use with automatic pool cleaners.



The Speck SUPER 90 Series features:

- a high resistance to corrosion and salt water
- maximum effectiveness at low power input
- the ultimate in reliability
- stability at high fluid temperatures up to 60°C
- no contact between motor and pump shaft with pool or spa water
- highest quality mechanical seal
- fan cooled - suitable for high ambient temperatures
- closed impeller
- stainless steel motor shaft
- easy to remove clear strainer lid
- every pump factory wet tested for quality control
- five year warranty

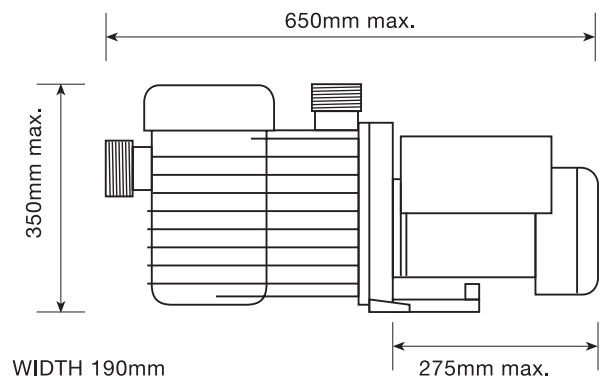

## Warranty Conditions - Residential Pools and Spas

Five (5) Year Factory Warranty on the following wet end components: Casing, Diffuser, Gland Housing, Impeller and Mechanical Seal.

Two (2) year warranty on motor and in all commercial applications.

Warranty includes manufacturing faults only and not labour or freight.

Model Code	Input Watts	Nominal Input HP
90 / 230	1000	1.0
90 / 350	1100	1.25
90 / 400	1300	1.5
90 / 500	1500	2.0
90 / 500 DS (Dual Speed)	300 low 1400 high	0.75 low 2.0 high

## PUMP PERFORMANCE

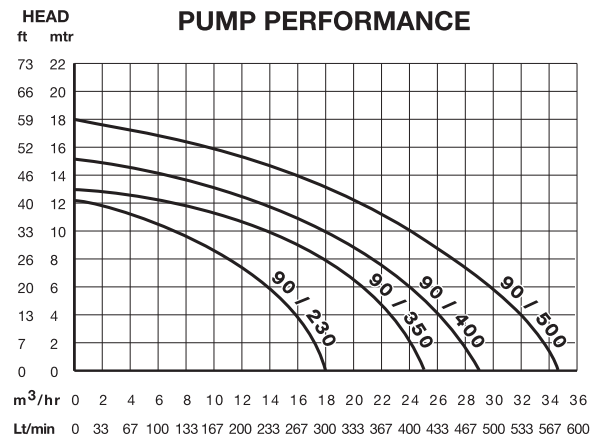

**Continental**  
Water Systems Pty Ltd  
ABN 71 050 287 735

**Designed and manufactured for  
Australian Conditions**

The manufacturer reserves the right to alter any specifications without notice

### Sydney Office

PO Box 297  
Seven Hills NSW 1730  
Unit 2 / 5 Anvil Road  
Seven Hills NSW 2147  
Australia  
T: 02 9838 8111  
F: 02 9838 7030  
E: sales@continentalwater.com.au  
accounts@continentalwater.com.au

### Gold Coast Office

Unit 2/13 Geary Crescent  
Molendinar QLD 4214  
Australia  
T: 07 5527 8122  
F: 07 5527 8533  
E: cwsspeck@bigpond.net.au

### Melbourne Office

Unit 17/200 Canterbury Road  
Bayswater North VIC 3153  
Australia  
T: 03 9720 4955  
F: 03 9720 3304  
E: continentalwater@bigpond.com

### Automated Pool Products

102 Burswood Road  
Burswood WA 6100  
Australia  
T: 08 9362 4022  
F: 08 9361 3913  
E: info@autopool.com.au

### Austral Distributors Limited

4 Hannigan Drive  
Mt Wellington Auckland  
New Zealand  
T: ++64 9 570 9570  
F: ++64 9 527 7641  
E: info@austral.co.nz

Web Site: [www.continentalwater.com.au](http://www.continentalwater.com.au)



## speck SUPER 90 SERIES

### Features

- Improved flow rate, 230 to 500 litres per minute
- Easy to remove non-corrosive lid with handle
- Robust construction, highest quality materials
- Quieter, smoother performance
- Giant strainer in all pump sizes
- Available in 1.0 to 2.0 HP

manufactured in Australia by

