

# Waterblade® Installation Manual

The Waterblade® is available in standard widths from 300mm to 2.4 metres. This unit must be installed according to these instructions; otherwise the [warranty](#) may be void.

Read and save these instructions.

## First steps

Check the illustrations to identify each individual part of the Waterblade® and use this manual to guide you through a trouble-free installation. It was developed with the aid of experienced installers to ensure consistent and hassle-free installation.

Take care not to damage the Waterblade® during installation. It is best to keep it in its original packaging until you are ready to begin the actual installation. Do not leave uninstalled Waterblade in direct sunlight. The Waterblade® is shipped complete with grout guard fitted in the opening of the waterfall to keep the spillway opening clean and to prevent damage. See below.

Do not remove the protective grout guard until you are ready to start up for the first time. Leave it in place throughout the installation or damage may occur which will affect the performance.

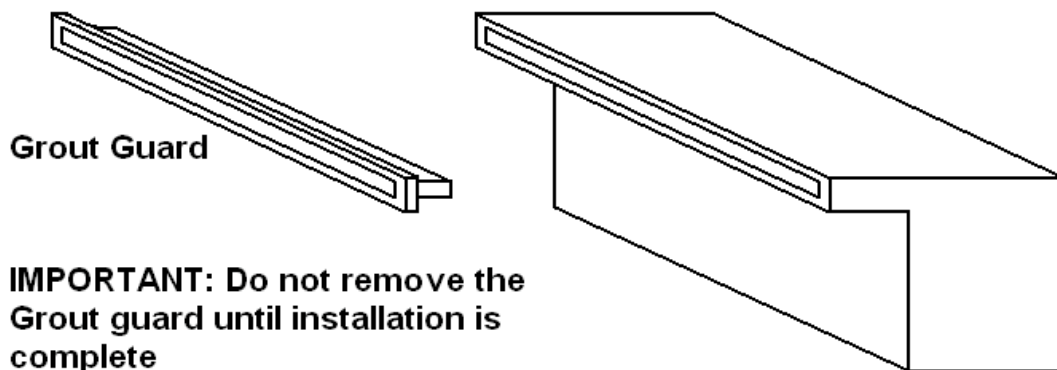

## Installing your Waterblade®

The pool tiler usually installs the Waterblade® waterfall. Be sure to install the waterfall before any decks or coping are to cover the Waterblade.

Place the Waterblade® in the pre-cut notch in the brick work (see below), then level the top of the unit to the top of the brick work using tile shims underneath the unit if necessary.

**Note:** the opening and grout guard are located at the top of the Waterblade®. Fill the gaps around the unit with suitable mastic material.

Cut tiles to fit beneath the lip of the unit and secure with tiling compound.

## Installation of 25mm lip Waterblade®

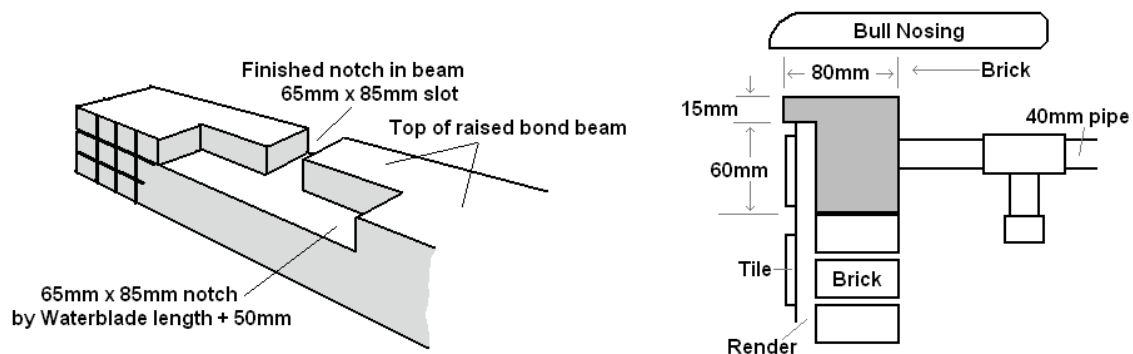

## Bottom-Feed Unit

A bottom-feed unit may be installed where space behind the unit is limited such as up against brick walls

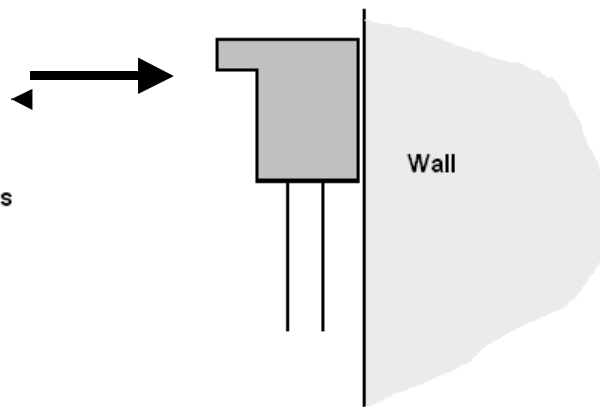

# Fibre Optic Units

These instructions are based on a basic unit. Fibre Optic units are available and if you are installing one of these, add a further 25mm at the top of the unit when cutting the recess for the unit. Fibre Optic units have a chamber at the top of the water blade where the fibres are introduced in the main manifold. Tile shims may be used to level the top of the unit. The Light Engine should be mounted as close to the Waterblade® as possible, in an accessible area so the light array may be altered or for service of the unit. Do not for any reason cut the Fibre Optic cable.

## Cutting the brick work

### 1. For Waterblade® models 300mm to 1200 mm long with 25mm lip.

After choosing the position for the Waterblade®, cut a notch in the brick work 85mm deep by 65mm wide and 50mm longer than the length of the Waterblade® (i.e. 25mm each end). For example, if you are installing the 1200mm model cut the notch 1250mm (1200 + 25 + 25 mm) long. Then mark a single slot in the centre and on top of the brick 65mm wide by 85mm deep. Use this notch to plumb 40mm PVC pipe to the Waterblade®. Mark the brick work and cut it accordingly.

Do not apply torque to fittings. Keep all piping supported so as not to stress the rear of the unit or fitting.

### 2. For Waterblade® models 1500 to 2400 mm long (dual feed).

Longer waterfalls need more water, therefore cut two plumbing lines. Mark and cut the brick as above, except that you now need two notches on the top of the brick for piping. Mark the top of the brick for these units as below.

LENGTH OF UNIT	POSITION OF DUAL FEED PIPES
1500mm	375mm either side of centre
1800mm	450mm either side of centre
2400mm	600mm either side of centre

Complete the cuts in the brick before moving on to the next stage.

### 3. Installation of 150-230mm Lip extension Units.

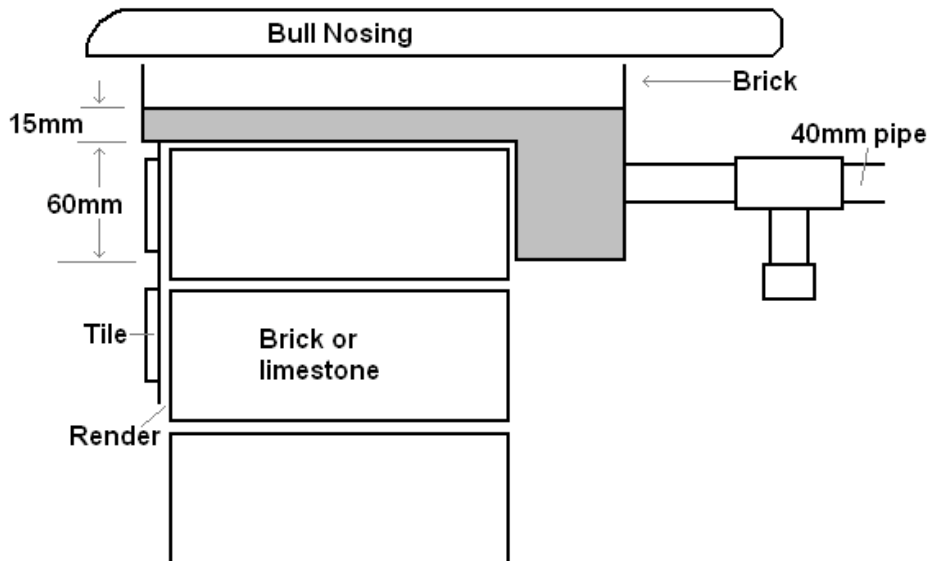

Place the Waterblade<sup>®</sup> unit on the flat, smooth, level surface in the correct location. Set it on the brick or concrete wall using cement or flexible adhesive. If you wish to install the unit so it sits flush with the top of the wall or bricks, mark the desired position and cut a recess into the top of the wall allowing the 25mm each end as stated previously and also allow for 10mm above and below the lip. Allow 25mm above the lip for a Fibre Optic unit instead of 10mm. Fill the area above and below the lip with suitable flexible adhesive.

Keep the waterfall unit shielded from the sun until the finishing coping has been positioned. Do not apply torque to fittings. Support all the piping so that the rear of the unit or fitting is not stressed.

## Waterfall Flow Volume

**Note:** When you are plumbing more than one waterfall, add the total length of waterfalls together to determine the flow rate required. E.g. When plumbing two 1800mm units, you now have 3600mm of waterfall, which needs 540 litres/min.

See flowchart (next page) to select the preferred volume of water flow, depending on how far forward you want the water sheet to project and how high your unit is above water level.

Approximate Projection of Sheet of Water per 300mm of Waterfall Length

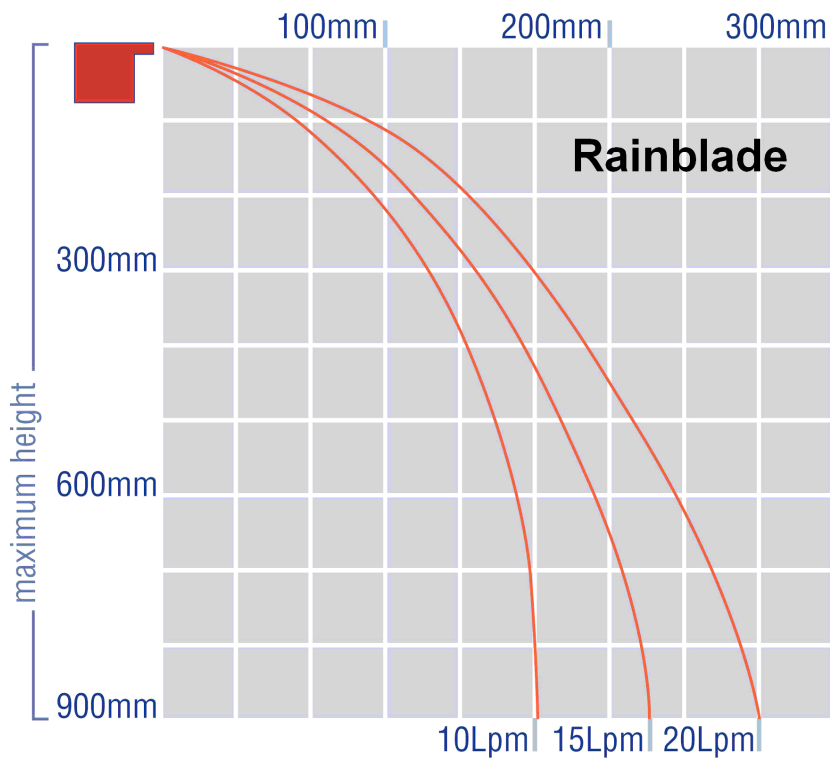

Approximate Projection of Sheet of Water per 300mm of Waterfall Length

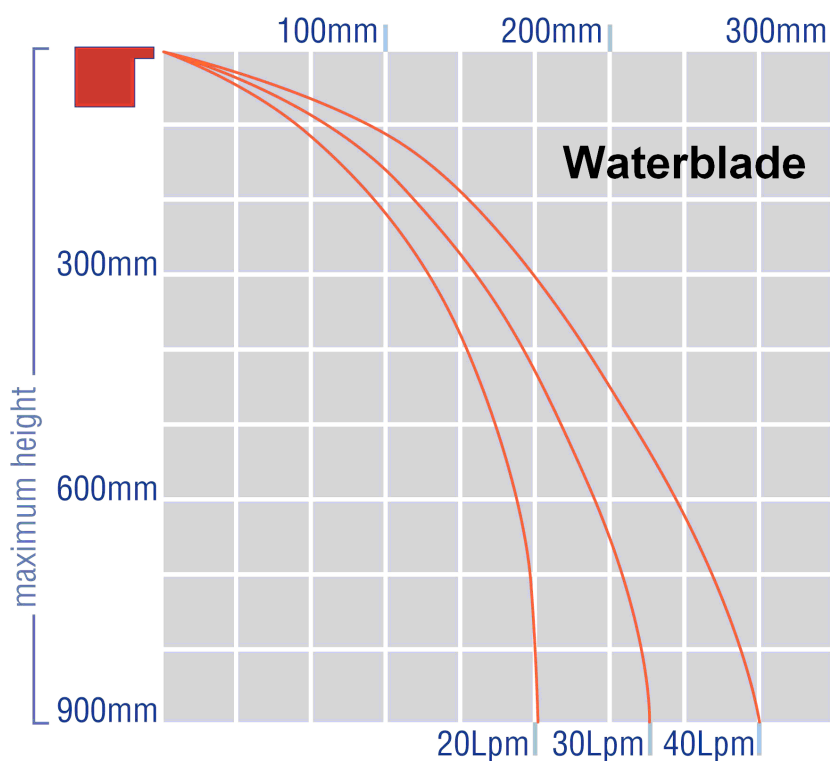

1. Determine how long your unit is
2. Measure how high it is above water level
3. Decide on an approximate projection between 200mm & 300mm from the wall.
4. Divide the length of your blade by 300 and this will determine by how much you need to times that by with the 'Litres per minute' value on the bottom axis. That calculation will give you the approximate flow of pump required.
5. Example: a 1200mm waterblade 900mm high with a proposed projection of 300mm (normal installation).  
 $1200 \div 300 = 4$
6.  $45\text{L}/\text{min} \times 4 = 180$ . This means you will need a pump that can handle 180L/min. Don't forget you will have restrictions of flow such as elbows & plumbing and a 2 or 3 way valve to control the flow, and a non return valve in some installations.

## When to install a separate pump for the Waterblade®

If you plan to install more than one Waterblade® wider than 1.8m, you will get better results by using a separate pump. For this you require a separate suction pipe of at least 50mm PVC.

Install a minimum of two safety suctions in the pool wall – check with your local council or industry body such as SPASA for local laws on location of safety suctions. Also plumb a filter on the return side of the pump, between the pump and the waterfall. See the **Cartridge Filters section on the Monarch Pool Systems website ([www.monarchpoolsystems.com](http://www.monarchpoolsystems.com)) for a suitable Cartridge Filter**. A suitable strainer may also be used, but a Cartridge filter is preferred as this will provide fully filtered water to the unit. Also install a two way valve to allow the operator to adjust the flow to the unit.

## Options for pump size and installation

The Waterblade® can provide a continuous sheet of water with a minimum rate of water flow. A standard 1200mm model, for example, requires only 180 litres of water per minute to project the blade of water 300mm at a height of 900mm.

Once the desired flow has been established, then refer to the Swimming Pool & Spa Pump section on the Monarch Pool Systems website ([www.monarchpoolsystems.com](http://www.monarchpoolsystems.com)) to select the desired model.

## Installing with existing pool filter pump in place

The most common plumbing system consists of using the existing main pool filter pump to supply the waterfall. This works well with a very small water flow. A correctly sized swimming pool pump will normally operate the Waterblade® and the pool filter at the same time with little change in overall flow rate. As a rule of thumb, the Waterblade® requires about 45 litres per minute (L/min) per 300mm of width with little head loss. However, you can increase the water flow rate to make a more dramatic effect and to project the water sheet further out from the wall. Install a three-way valve on the line returning water from the filter to the pool and connect it to the waterfall feed line with 40mm PVC pressure pipe. Waterfalls more than 1500mm wide require at least a 50mm PVC feed pipe. **Note: •Use minimum of 40mm pipe. Use minimum of 50mm pipe for runs of more than 20m or if waterfall is more than 1500mm wide. Use dedicated plumbing lines.**

## Plumbing in the Waterblade®

Return line: The feed line from either the main pump or a separate pump requires at least 40mm PVC pipe. Use a 50mm line for waterfalls wider than 1.5m. Place the end point of the feed line near the centre of the waterfall at the rear of the bond beam.

When using the existing filter pump, install a three-way valve as the "T" from the return line of the pool to the Waterblade®. Place it in an accessible position on the feed line so that you can control the flow rate of water to the Waterblade® as well as to the rest of the pool. The best place for this valve is usually just after the filter near the equipment pad.

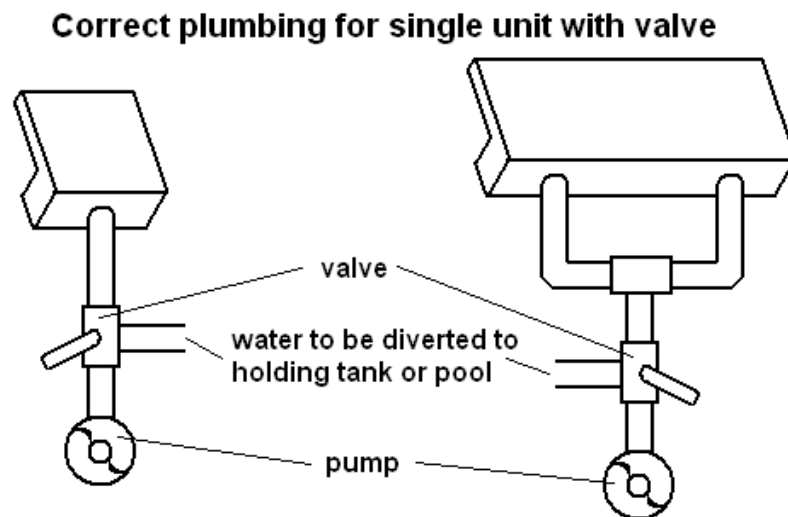

**NB** Filter all water supplied to the Waterblade®. If you have a dedicated pump for the Waterblade® you must use a separate filter to keep debris out of the unit.

Standard 40mm PVC fittings will fasten to the 40mm fitting provided on all Waterblade® units using standard PVC solvent cement.

To ensure fittings are properly bonded when gluing, clean both pipe and fittings before applying solvent cement, smear both parts with solvent cement and slightly twist the pipe when pushing it into the fitting. Priming fluid may be used if desired.

Install the rock trap as close to the waterfall as possible. See below for installation instructions.

**Note:** You should install a flow control valve in an accessible position on the supply line to regulate the water supply to the Waterblade®.

## Installing multiple units

You can install multiple Waterblade® units in exactly the same way as for a single unit except that you will need to include a separate two-way valve for each unit. These valves are used to control the amount and distribution of water between each of the waterfall units. Use minimum 50mm PVC pipe with regulating valves for 1500mm and wider.

**Correct plumbing for multiple units with valve (a valve for each unit is preferred)**

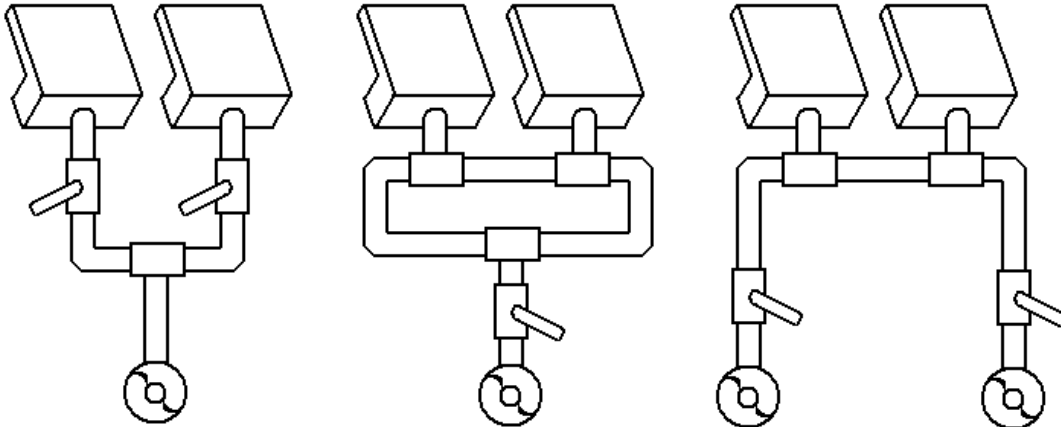

## Installing the rock trap (optional on some Waterblade® models)

- Install the rock trap close to the waterfall for maximum protection.
- Make sure the debris collection chamber is pointing down. If this is not possible do not install the rock trap.
- Before cementing the rock trap in place make sure the flow arrow is pointing in the right direction.

## Waterblade® Radius Cut

Concave and convex cuts can be made to order.

Contact your Waterblade® dealer to discuss your requirements.

## Starting Up Your Waterblade®

The Waterblade® is ready to be started as soon as the swimming pool is finished and filled with water and all glue and/or fixing adhesives are given sufficient time to dry. Remove the protective grout guard now and make sure the opening is clean and free from debris before diverting water into the waterfall.

Now switch the pump on. If you are using the main pool pump to supply the waterfall let it run for a few minutes to clear all debris out of the lines. Then slowly open the valve and allow water to flow to the Waterblade® unit. Using the three-way valve, adjust the water flow rate until the sheet of water projects on to the surface of the swimming pool.

After a few minutes all air should have been cleared from the lines and the Waterblade® should now provide a continuous sheet of water.

If you have installed a separate pump, be certain to open all valves before starting the pump. Make sure all lines are clear of debris, then start the pump and let water circulate through the filter and return system. Close the valve to the waterfall slowly until it has reached your desired flow rate. Wait for a few minutes until all air has been forced out of the pipes.

## Winterisation

In areas where a heavy frost is likely, drain water from the system during winter. In these areas, the plumbing should be designed for ease of draining water. The Waterblade® is designed so that only a minimum of water stays in the unit when the plumbing is installed correctly.

For winterising, blow all lines clear of water and follow normal procedures such as covering the pool.

## Trouble shooting

1. Check that the pump system is switched on and working normally.
2. Make sure all air is purged from the lines
3. Make sure all filters and strainers are cleaned
4. Make sure valves have not been tampered with

<b>Problem</b>	<b>Cause</b>	<b>Solution</b>
Waterfall is not completely smooth. There is a gap in the water sheet	Debris has collected in the manifold and is stuck behind the opening	Place a credit card or similar slim object inside the opening while the waterfall is running. Slide it along to where the debris is and gently pull it out.
One waterfall is stronger than another (where there are more than one waterfall)	Water supply not correctly balanced	Adjust three-way valves until balance correct

## Warranty

Your Waterblade<sup>®</sup> comes with a 12 month warranty. This warranty is limited to manufacturing defects only and does not cover any such damage caused by misuse or installation error. Take care whilst installing your new Waterblade<sup>®</sup> and do not leave it in direct sunlight prior to installation.